

Features

- Micro-power consumption
- 2.0V~5.0V power supply
- Chopper stabilized amplifier stage
- Push-pull output
- Switching for both polar of a magnet
- High Sensitivity Hall Sensor
- Package: SOT23-3L

Applications

- Solid State Switch
- Home appliances, consumer
- Proximity Switch
- Position Detection

General Description

The AH213AT0 is fabricated from mixed signal CMOS technology. It internally includes an on-chip Hall voltage generator, a voltage regulator for operation with supply voltages of 2.0 to 5.5V, asleep/awake logic for low power consumption, temperature compensation circuitry, small-signal amplifier, Hall sensor with dynamic offset cancellation system, Schmitt trigger and an open-drain output. Either north or south poles of sufficient strength

will turn the sensor output on. The output will be turned off under no magnetic field. While the magnetic flux density (B) is larger than operating point (Bop), the output will be turned on (low), the output is held until B is lower than release point (Brp), and then turned off.

The total power consumption in normal operation is typically 20μW with a 3.3V power source. Operating temperature range of the AH213AT0 is from -40°C to 85°C.

Block Diagram

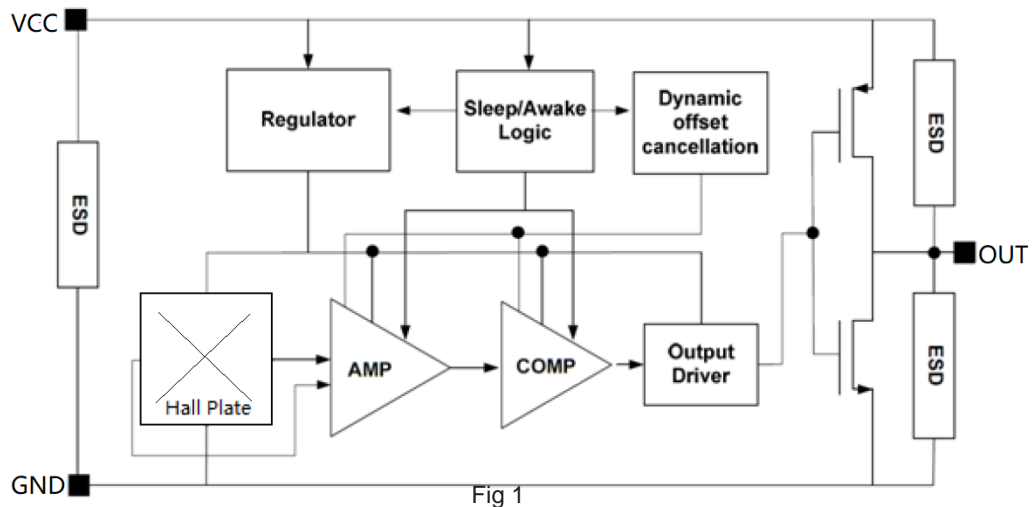

Pin Assignment and Marking

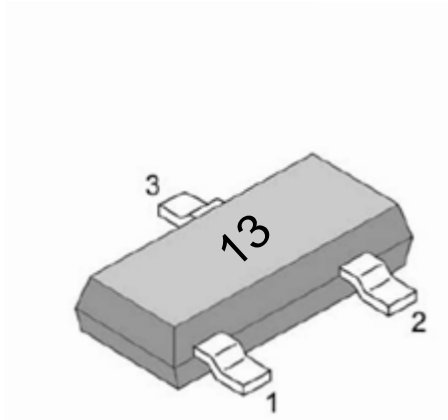

Fig2 SOT23-3L

Pin Description

SOT Pin Number	Pin Name	Function
1	VCC	Supply Voltage
2	OUT	Open Drain Output
3	GND	Ground

Marking :13

Order Information

Part number	Description
AH213AT0	SOT23-3L package, tape and reel packaging(3000pcs/bag),RoHS/Pb Free

Absolute Maximum Ratings

Symbol	Parameter	Value	Unit
V _{cc}	Supply Voltage	-0.5~6.0	V
I _{dd}	Supply Current	5	mA
B	Magnetic Flux Density	Unlimited	Gauss
T _j	Operating Junction Temperature Range	-40 to 150	°C
T _s	Storage Temperature	-65 to 150	°C
PD	Power Dissipation	SOT23-3L 230	mW

Note: Stresses greater than those listed under "Absolute Maximum Ratings" may cause permanent damage to the device. These are stress ratings only, and functional operation of these or any other conditions beyond those indicated under "Recommended Operating Conditions" is not implied. "Absolute Maximum Ratings" for extended period may affect device reliability.

Recommended Operating Conditions

(TA=25°C unless otherwise noted)

Parameter	Symbol	Min	Max	Unit
Supply Voltage	V _{CC}	2.0	5.0	V
Ambient Temperature	T _a	-40	85	°C

Electrical Characteristics

(V_{CC}=3.3V T_a=25°C, unless otherwise specified)

Symbol	Parameter	Test Conditions	Min.	Typ.	Max.	Unit
I _{CC}	Average Supply Current	V _{CC} =2.7V, Output Open	-	4	7	µA
I _{ON}	Supply current (operating mode)	V _{CC} =3.3V	-	1.2	-	mA
I _{ST}	Supply current (stand-by mode)	V _{CC} =3.3V	-	3	-	µA
V _{SAT}	Output Saturation Voltage	I _o =2mA, B>B _{op}	-	-	0.1	V
I _{OL}	Output Leakage Current	V _{out} =5.0V, B<B _{rp}	-	-	1	µA
T _{awake}	Awake Time	V _{CC} =3.3V	-	90	-	µs
T _{period}	Period	V _{CC} =3.3V	-	55	-	ms
ESD	Electro-Static Discharge	HBM	-	4	-	KV

Magnetic Characteristics

(V_{CC}=3.3V T_a=25°C, unless otherwise specified)

Characteristics	Symbol	Min	Typ	Max	Unit
Operating Point	B _{ops} (south pole to part marking side)	-	+35	+55	Gauss
	B _{opn} (north pole to part marking side)		-35	-55	Gauss
Releasing Point	B _{rps} (south pole to part marking side)	+8	+25	-	Gauss
	B _{rpn} (north pole to part marking side)	-8	-25	-	Gauss
Hysteresis	B _{hys} = B _{opx} -B _{rp_x}	3	10	18	Gauss

Package Information

PACKAGE DESIGNATOR

SOT23-3L
(AH213AT0)

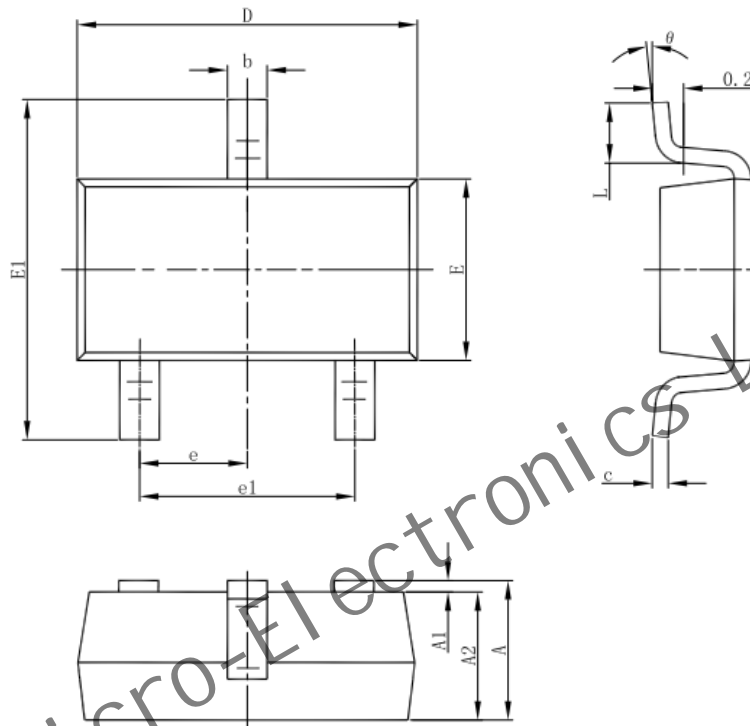

Symbol	Dimensions In Millimeters		Dimensions In Inches	
	Min	Max	Min	Max
A	1.050	1.250	0.041	0.049
A1	0.000	0.100	0.000	0.004
A2	1.050	1.150	0.041	0.045
b	0.300	0.500	0.012	0.020
c	0.100	0.200	0.004	0.008
D	2.820	3.020	0.111	0.119
E	1.500	1.700	0.059	0.067
E1	2.650	2.950	0.104	0.116
e	0.950(BSC)		0.037(BSC)	
e1	1.800	2.000	0.071	0.079
L	0.300	0.600	0.012	0.024
θ	0°	8°	0°	8°



AH213AT0

Omnipolar Hall-Effect Switch

©Asic Micro-Electronics Limited

ASIC cannot assume responsibility for use of any circuitry other than circuitry entirely embodied in a ASIC product. No circuit patent license, copyrights or other intellectual property rights are implied. ASIC reserves the right to make changes to their products or specifications without notice. Customers are advised to obtain the latest version of relevant information to verify, before placing orders, that information being relied on is current and complete.

ASiC Micro-Electronics Limited