

1. Product Summary

$V_{(BR)DSS}$	$R_{DS(on)TYP}$	I_D
60V	70mΩ@10V	3A
	85mΩ@4.5V	

2. Features

- V_{DS} 60V
- I_D 3A
- $R_{DS(ON)}$ (at $V_{GS}=10V$) < 100 mohm
- $R_{DS(ON)}$ (at $V_{GS}=4.5V$) < 120 mohm
- High power and current handing capability
- Surface mount package

3. Applications

- Battery Switch
- DC/DC Converter

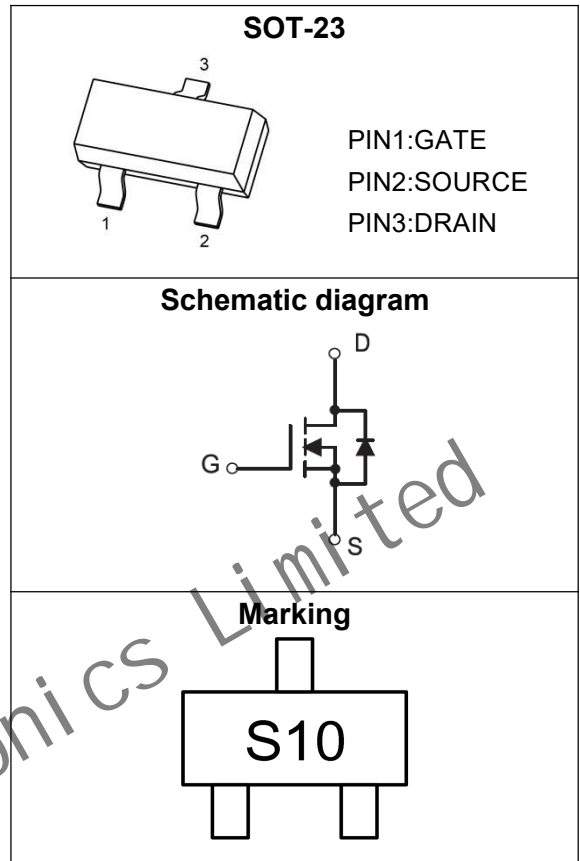

4. Absolute Maximum rating ($T_A = 25^\circ C$ unless otherwise noted)

Parameter	Symbol	Value	Unit
Drain - Source Voltage	V_{DS}	60	V
Gate - Source Voltage	V_{GS}	±20	V
Continuous Drain Current ^{1,5}	I_D	3	A
Pulsed Drain Current ²	I_{DM}	10	A
Power Dissipation ^{4,5}	P_D	1.5	W
Thermal Resistance from Junction to Ambient	$R_{\theta JA}$	83.3	°C/W
Junction Temperature	T_J	150	°C
Storage Temperature	T_{STG}	-55~ +150	°C

5. Electrical Characteristics (T_A = 25°C unless otherwise noted)

Parameter	Symbol	Test Condition	Min	Type	Max	Unit
Static Characteristics						
Drain - Source Breakdown Voltage	V _{(BR)DSS}	V _{GS} = 0V, I _D = 250μA	60			V
Zero Gate Voltage Drain Current	I _{DSS}	V _{DS} = 60V, V _{GS} = 0V			1	μA
Gate - Body Leakage Current	I _{GSS}	V _{GS} = ±20V, V _{DS} = 0V			±100	nA
Gate Threshold Voltage ³	V _{GS(th)}	V _{DS} = V _{GS} , I _D = 250μA	0.9	1.3	2	V
Drain-source On-resistance ³	R _{DS(on)}	V _{GS} = 10V, I _D = 3A		70	100	mΩ
		V _{GS} = 4.5V, I _D = 3A		85	120	
Forward transconductance ³	g _{FS}	V _{DS} = 15V, I _D = 2A	1.4	2.5		S
Dynamic Characteristics						
Input Capacitance	C _{iss}	V _{DS} = 30V, V _{GS} = 0V, f = 1MHz		250		pF
Output Capacitance	C _{oss}			26		
Reverse Transfer Capacitance	C _{rss}			20		
Switching Characteristics						
Total Gate Charge	Q _g	V _{DS} = 30V, V _{GS} = 4.5V, I _D = 3A		7		nC
Gate-source Charge	Q _{gs}			1.2		
Gate-drain Charge	Q _{gd}			1.5		
Turn-on Delay Time	t _{d(on)}	V _{GS} = 10V, V _{DD} = 30V, I _D = 1.5A, R _{GEN} = 1Ω		6.5		ns
Turn-on Rise Time	t _r			15.2		
Turn-off Delay Time	t _{d(off)}			15.2		
Turn-off Fall Time	t _f			10.3		
Source - Drain Diode Characteristics						
Diode Forward Voltage ³	V _{SD}	V _{GS} = 0V, I _S = 1A			1.2	V

Notes :

- The maximum current rating is limited by package.
- Pulse Test : Pulse Width ≤ 10μs, duty cycle ≤ 1%.
- Pulse Test : Pulse Width ≤ 300μs, duty cycle ≤ 2%.
- The power dissipation PD is limited by T_{J(MAX)} = 150°C.
- Device mounted on 1in² FR-4 board with 2oz. Copper, in a still air environment with T_A = 25°C.

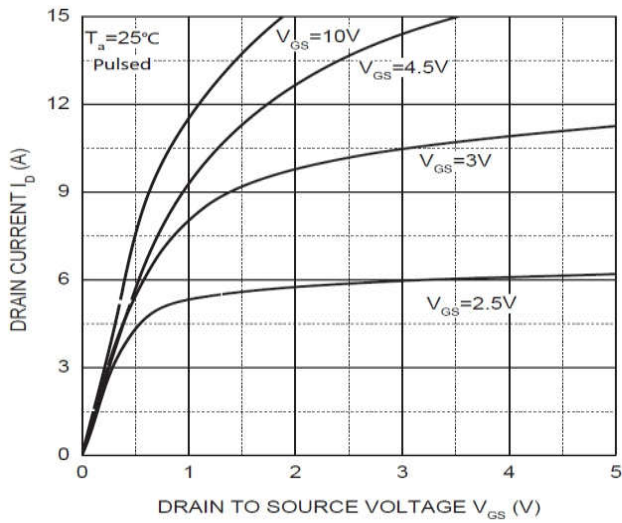
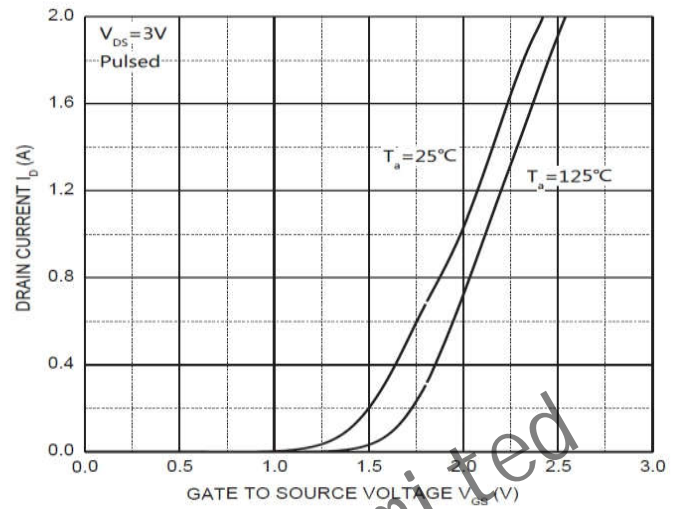
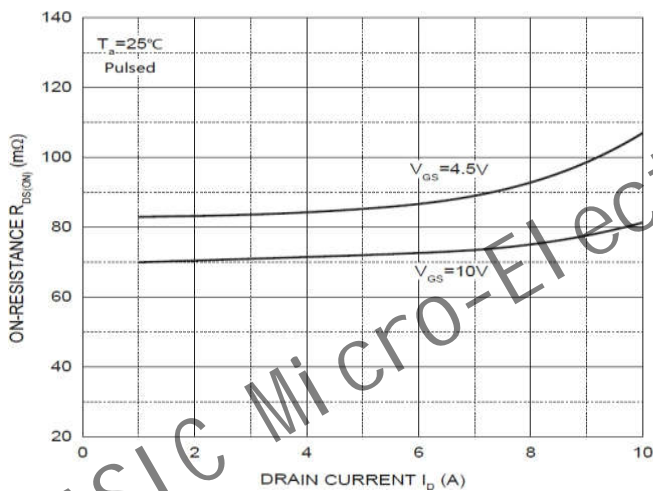
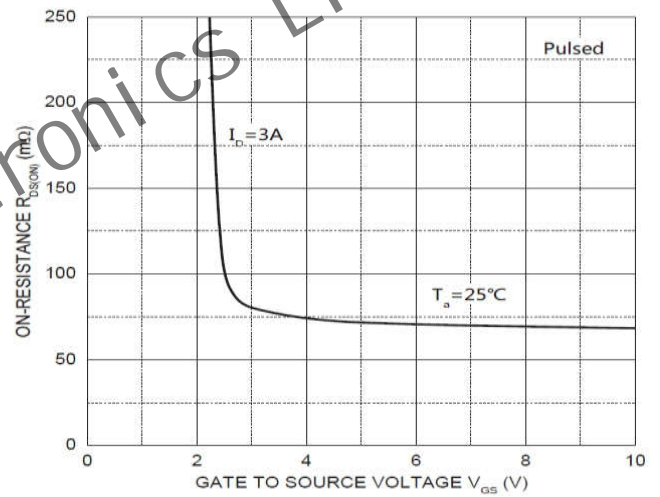
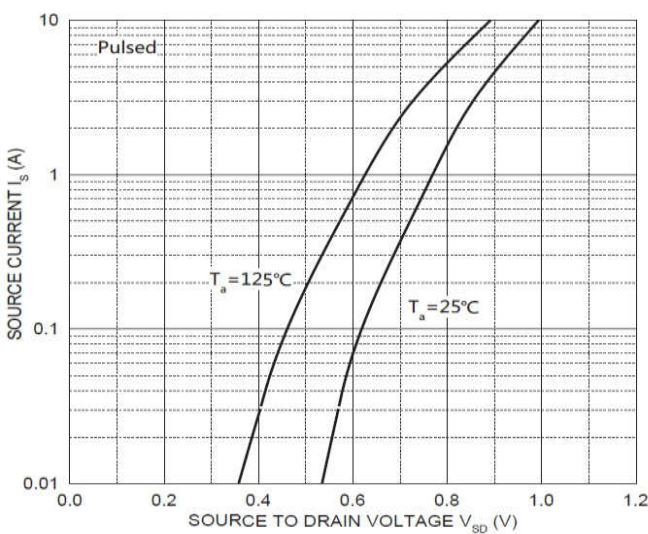
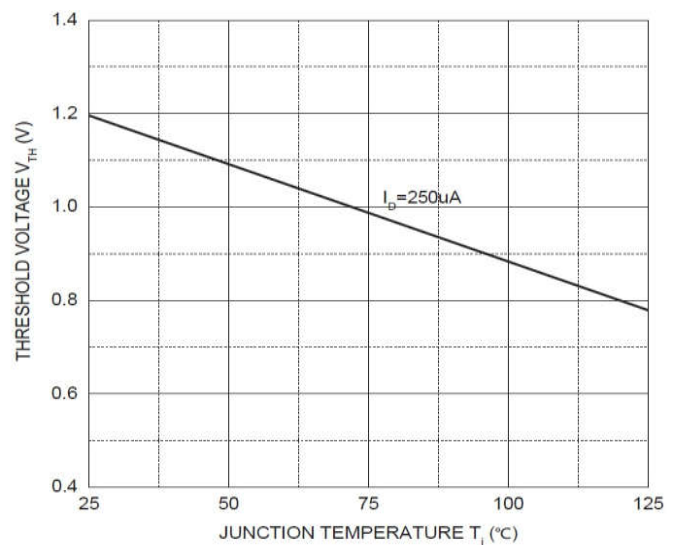
6. Typical Characteristic

Output Characteristics

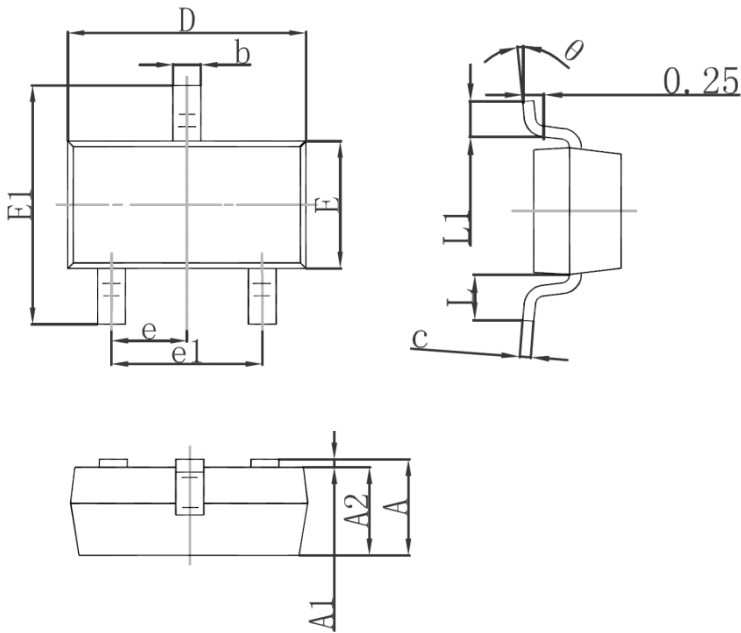
Transfer Characteristics

 $R_{DS(ON)}$ — I_D

 $R_{DS(ON)}$ — V_{GS}

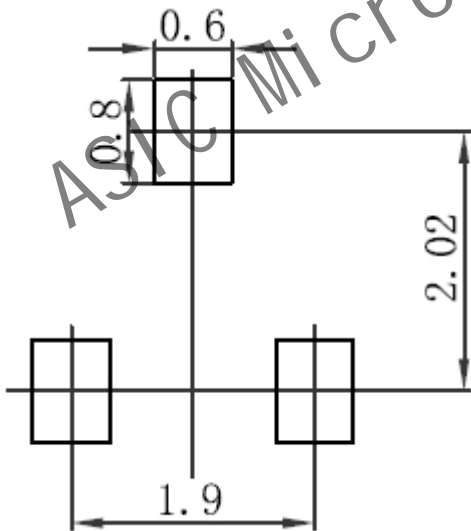
 I_S — V_{SD}

Threshold Voltage

7.Dimension



Symbol	Millimeters		Inches	
	Min	Max	Min	Max
A	0.900	1.150	0.035	0.045
A1	0.000	0.100	0.000	0.004
A2	0.900	1.050	0.035	0.041
b	0.300	0.500	0.012	0.020
c	0.080	0.150	0.003	0.006
D	2.800	3.000	0.110	0.118
E	1.200	1.400	0.047	0.055
E1	2.250	2.550	0.089	0.100
e	0.950 TYP		0.037 TYP	
e1	1.800	2.000	0.071	0.079
L	0.550 REF		0.022 REF	
L1	0.300	0.500	0.012	0.020
θ	0° - 8°		0° - 8°	

8.Recommended Land Pattern



Note:

1. Controlling dimension: in millimeters
2. General tolerance: $\pm 0.05\text{mm}$
3. The pad layout is for reference only
4. Unit: mm

9. Tape and Reel

SOT-23 Embossed Carrier Tape

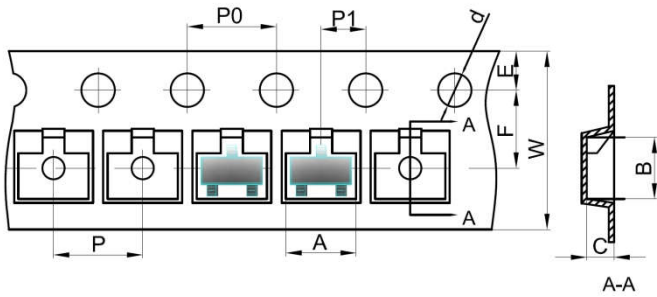

Packaging Description:

SOT-23 parts are shipped in tape. The carrier tape is made from a dissipative (carbon filled) polycarbonate resin. The cover tape is a multilayer film (Heat Activated Adhesive in nature) primarily composed of polyester film, adhesive layer, sealant, and anti-static sprayed agent. These reeled parts in standard option are shipped with 3,000 units per 7" or 17.8cm diameter reel. The reels are clear in color and is made of polystyrene plastic (anti-static coated).

Dimensions are in millimeter										
Pkg type	A	B	C	d	E	F	P0	P	P1	W
SOT-23	3.15	2.77	1.22	Ø1.50	1.75	3.50	4.00	4.00	2.00	8.00

SOT-23 Reel

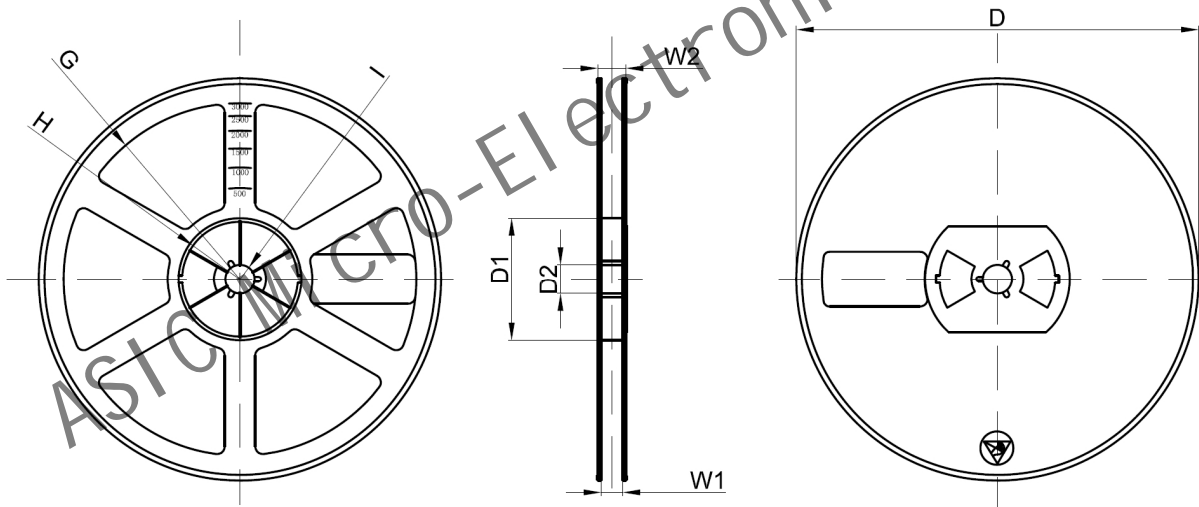

Dimensions are in millimeter								
Reel Option	D	D1	D2	G	H	I	W1	W2
7" Dia	Ø178.00	54.40	13.00	R78.00	R25.60	R6.50	9.50	12.30

REEL	Reel Size	Box	Box Size(mm)	Carton	Carton Size(mm)	G.W.(kg)
3000 pcs	7 inch	45,000 pcs	203×203×195	180,000 pcs	438×438×220	

DISCLAIMER

ASIC PROVIDES TECHNICAL AND RELIABILITY DATA (INCLUDING DATASHEETS), DESIGN RESOURCES (INCLUDING REFERENCE DESIGNS), APPLICATION OR OTHER DESIGN ADVICE, SAFETY INFORMATION, AND OTHER RESOURCES "AS IS" AND WITH ALL FAULTS, AND DISCLAIMS ALL WARRANTIES, EXPRESS AND IMPLIED, INCLUDING WITHOUT LIMITATION ANY IMPLIED WARRANTIES OF MERCHANTABILITY, FITNESS FOR A PARTICULAR PURPOSE OR NON-INFRINGEMENT OF THIRD PARTY INTELLECTUAL PROPERTY RIGHTS.

These resources are intended for skilled developers designing with ASIC products. You are solely responsible for

- (1) selecting the appropriate ASIC products for your application,
- (2) designing, validating and testing your application
- (3) ensuring your application meets applicable standards, and any other safety, security, or other requirements. These resources are subject to change without notice. ASIC grants you permission to use these resources only for development of an application that uses the ASIC products described in the resource. Other reproduction and display of these resources are prohibited. No license is granted to any other ASIC intellectual property right or to any third party intellectual property right. ASIC disclaims responsibility for, and you will fully indemnify ASIC and its representatives against, any claims, damages, costs, losses, and liabilities arising out of your use of these resources. ASIC's products are provided subject to ASIC's Terms of Sale or other applicable terms available either on www.asicm.co or provided in conjunction with such ASIC products. ASIC's provision of these resources does not expand or otherwise alter ASIC's applicable warranties or warranty disclaimers for ASIC products

ASIC Micro-Electronics Limited