

SOD-523

SOD-523 贴片塑封肖特基二极管

SOD-523 Plastic-Encapsulate Schottky Barrier Diode



特征 Features

- 大电流承受能力。High Current Capability
- 正向压降低。Low Forward Voltage Drop

机械数据 Mechanical Data

Marking:



- 封装: SOD-523 封装 SOD-523 Small Outline Plastic Package
- 极性: 色环端为负极 Polarity: Color band denotes cathode end
- 安装位置: 任意 Mounting Position: Any

极限值和温度特性(TA = 25°C 除非另有规定)

Maximum Ratings & Thermal Characteristics (Ratings at 25°C ambient temperature unless otherwise specified.)

参数 Parameters	符号 Symbol	Value	单位 Unit
最大可重复峰值反向电压 Maximum repetitive peak reverse voltage	VRRM	40	V
最大均方根电压 Maximum RMS voltage	VRMS	28	V
最大直流阻断电压 Maximum DC blocking voltage	VDC	40	V
最大正向平均整流电流 Maximum average forward rectified current	IFM	350	mA
峰值正向浪涌电流 8.3ms 单一正弦半波 Peak forward surge current 8.3 ms single half sine-wave	IFSM	2	A
功率消耗 Power Dissipation	PD	150	mW
典型热阻 T ypical thermal resistance	RθJA	667	°C/W
工作结温 Operating junction temperature	Tj	125	°C
存储温度 Storage temperature range	TSTG	-50-+150	°C

电特性 (TA = 25°C 除非另有规定)

Electrical Characteristics (Ratings at 25°C ambient temperature unless otherwise specified).

参数 Parameters	符号 Symbol	测试条件 Test conditions	Min	TYP	Max	单位 Unit
最大正向电压 Maximum forward voltage	VF	IF = 1mA IF = 5mA IF = 20mA IF = 200mA		0.27 0.32	0.37 0.60	V
最大反向电压 Maximum reverse breakdown voltage	VR	IR=100uA	40			V
最大反向电流 Maximum reverse current	IR	VR=30V VR=20V VR=10V			5 2 1	uA
典型结电容 Total capacitance	Ctot	VR = 0V, f = 1MHz		50		pF
反向恢复时间 Reverse recovery time	Trr	IF=IR=200mA, Irr=0.1xIR, RL=100 Ω		10		ns

特性曲线 Characteristic Curves

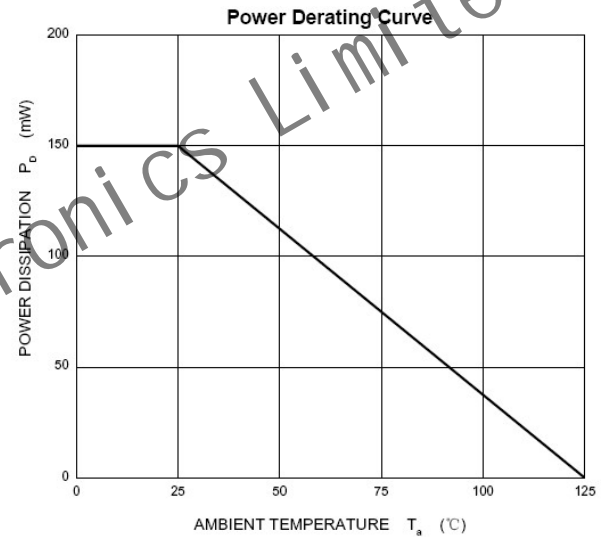
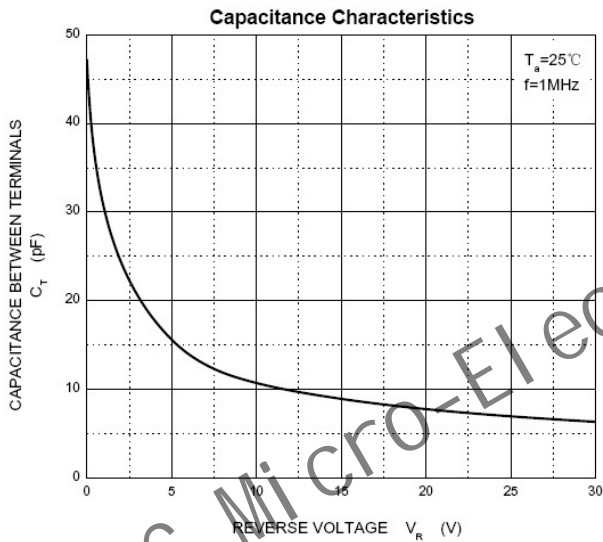
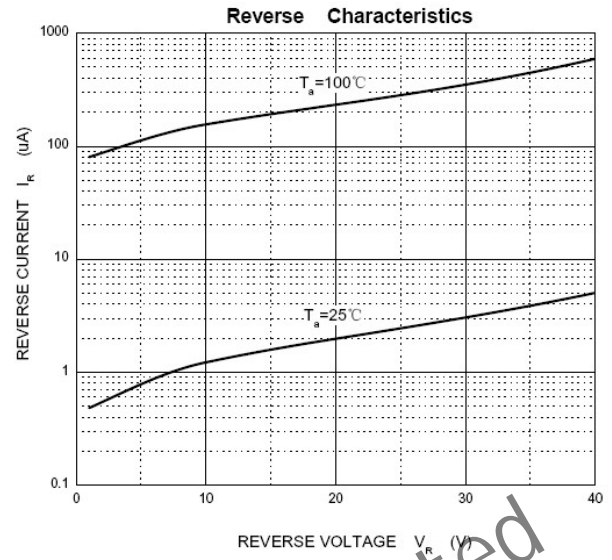
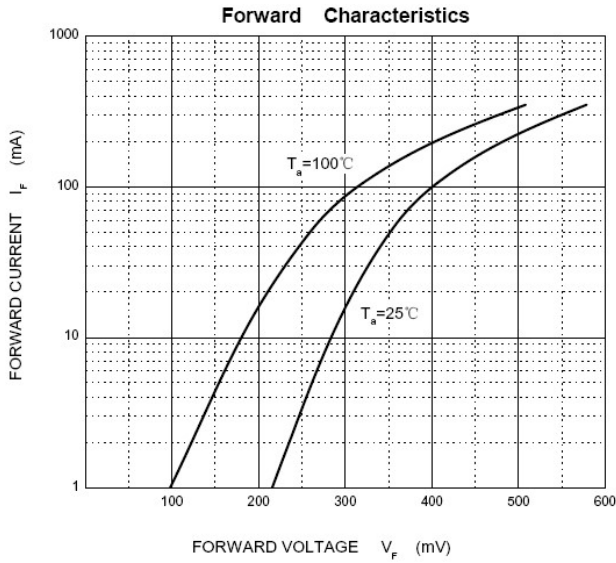

SOD-523 PACKAGE OUTLINE

Plastic surface mounted package

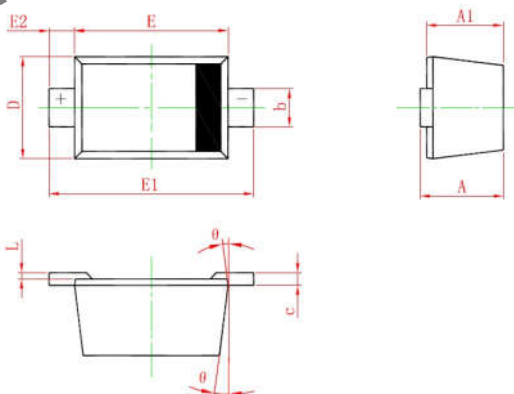

Symbol	Dimensions In Millimeters		Dimensions In Inches	
	Min	Max	Min	Max
A	0.510	0.770	0.020	0.031
A1	0.500	0.700	0.020	0.028
b	0.250	0.350	0.010	0.014
c	0.080	0.150	0.003	0.006
D	0.750	0.850	0.030	0.033
E	1.100	1.300	0.043	0.051
E1	1.500	1.700	0.059	0.067
E2	0.200 REF		0.008 REF	
L	0.010	0.070	0.001	0.003
θ	7° REF		7° REF	